



### Main Features:

1. Compact structure can save the installation space.
2. Low investment costs.
3. Light weight easy to replace and installation.
4. Perfect filter channel ensure the uniform airflow.
5. Leak Test for all the filters.

### Introducing:

Disposable HEPA & ULPA filters are available in efficiency ranges : 95%~ 99.99995%@MPPS (H11~U16) according to EN1822 testing standard. They are designed as a combined type air filter which consist of a HEPA box and a filter . Different diameter of the inlet collar are available, that can meet different installation environment .

### Construction:

Disposable HEPA & ULPA filters use a cylindrical bobbin for air inlet,that was easy to connect with the supply air duct . Air valve adjustment on the air inlet are available,that can control air volume rate , which have the effect of adjusting the filter surface wind speed.

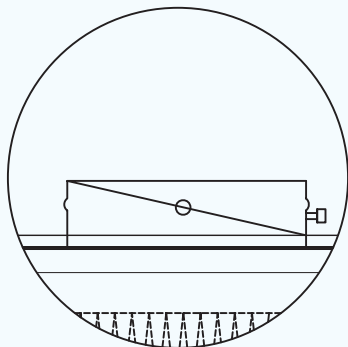

Air valve adjustment

Diffuser plate between the air inlet and the media pack made the air diffusion around the enclosure,that ensure the air through the filter uniformly . This design ensure the filter won't be failure on account of too big local air volume .

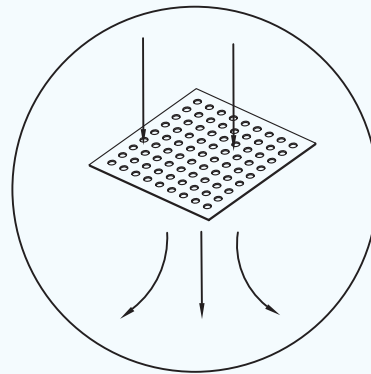

Diffuser plate

Disposable HEPA & ULPA filters use a diameter of 0.1~5um super fine Glass fibre for media,that ensure the filters has lower pressure drop, more dust holding and longer service life; Special processing made the media have the function of Water-resistance ;Such materials can be used in humid environments. The fine fiberglass media pleated to "V" shape to get lower pressure and better uniform airflow .Also the materials pleated to media packs with the fine hot melt separator can withstand wind speeds of 2m without damage.

Disposable HEPA&ULPA filters usually use extruded anodized aluminum profile to protect the frame does not corrode ; Insulation all around the extruded anodized frame made by PE foam, which was used for preventing water condensation on the frame surface .Also B2 Flammability rating of the PE foam are available , that according to the DIN 4102 standard.



PE foam

Disposable HEPA & ULPA filters are designed for cleanrooms from class 1 to class 100,000 . They use the professional polyurethane adhesive for sealant to connect the HEPA box and the media pack as a whole filter . This design have the benefit of avoid leakage and increase strength.

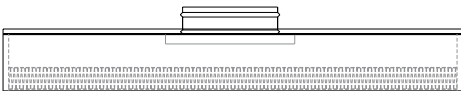

combination design

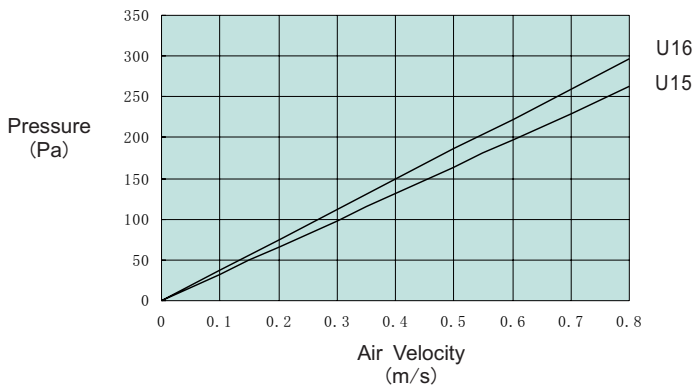

## Operating Conditions

- ※ Temperature:  $\leq 70^{\circ}\text{C}$
- ※ Humidity:  $\leq 100\% \text{RH}$

## Option:

1. Galvanized sheet, Stainless steel , Aluminum sheet frame are available
2. Different styles profiles are available
3. Low boron media is available
4. Dove tailed CR, EPDM, EVA gasket are available.
5. Aluminum mesh, Painted Expanded Metal face guard on upstream or downstream are available.
6. EN1822 Test for all the filters are available.

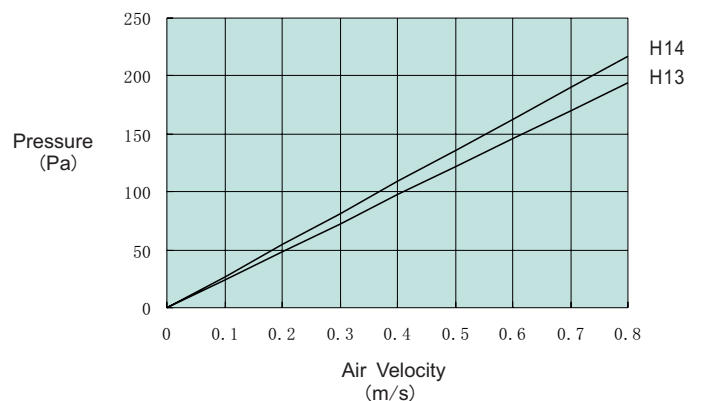

# Technical Parameters

## Disposable HEPA Filter

WxHxD (mm)	Area (m <sup>2</sup> )	Efficiency	Airflow (CMH)	Initial Pressure (Pa)	Airflow (CMH)	Initial Pressure (Pa) ※
600x600x150	10.60	H13	450	85	580	110
		H14		95		125
610x610x150	10.97	H13	465	85	600	110
		H14		95		125
1170x570x150	20.08	H13	840	85	1080	110
		H14		95		125
1210x600x150	21.88	H13	915	85	1175	110
		H14		95		125
1220x610x150	22.46	H13	935	85	1205	110
		H14		95		125

## Disposable ULPA Filter

WxHxD (mm)	Area (m <sup>2</sup> )	Efficiency	Airflow (CMH)	Initial Pressure (Pa)	Airflow (CMH)	Initial Pressure (Pa) ※
600x600x150	9.22	U15	450	115	580	145
		U16		130		165
610x610x150	9.50	U15	465	115	600	145
		U16		130		165
1170x570x150	17.40	U15	840	115	1080	145
		U16		130		165
1210x600x150	19.00	U15	915	115	1175	145
		U16		130		165
1220x610x150	19.52	U15	935	115	1205	145
		U16		130		165

※ Recommended final pressure: 600Pa

※ Pressure range 15%

※ Above parameters for your reference only, please consult our technical person regarding the detailed specific parameters difference.

※ Different size and specification are available.